



Circuit-Breaker Switchgear
Type SIMOPRIME A4, up to 24 kV, Air-Insulated
Medium-Voltage Switchgear

EDH

SIEMENS Technology

Application	Page
Benefits	2
Typical uses	2 and 3
Technical Data	
Ratings	4
Classification, dimensions, roomplanning	5
Product Range	
Panels	6
Design	
Panel design	7
Compartments, interlocks, operation	8
Benefits and features	9
Standards	
Standards, specifications, guidelines	10 and 11
Notes	
	12 and 13

Benefits (see also page 10 for details)

- Saves lives
- Peace of mind
- Increases productivity
- Saves money



The circuit-breaker switchgear type SIMOPRIME A4 is a factory assembled, type-tested switchgear for indoor installation according to IEC 62271-200 and VDE 0671-200. Loss of service continuity category: LSC 2B
Partition class: PM
Internal arc classification: IAC A FLR
arc duration: 1 or 0.1 s

SIMOPRIME A4 panel
Maximum ratings 24 kV / 25 kA / 2500 A

Typical uses

The SIMOPRIME A4 circuit-breaker switchgear can be used in transformer and switching substations, e.g.:

Application: Power supply system

- Power supply companies

Application: Industry

- Power stations
- Cement industry
- Automobile industry
- Iron and steel works
- Rolling mills
- Mining industry
- Textile, paper and food industries

- Chemical industry
- Petroleum industry
- Pipeline installations
- Offshore installations
- Electrochemical plants
- Petrochemical plants
- Shipbuilding industry
- Diesel power plants
- Emergency power supply installations
- Lignite open-cast mines
- Traction power supplies



Application

Typical uses

Application
Industry



Application
Public power
supply system



**SIMOPRIME A4
switchgear**



Application
Industry



EDH factory

Technical Data

Ratings

Electrical data (maximum values) of SIMOPRIME A4

Ratings	Rated values (max.)
Switchgear up to 24 kV	
Rated voltage	24 kV
Rated frequency	50/60 Hz
Rated short-duration power-frequency withstand voltage	50 kV
Rated lightning impulse withstand voltage	125 kV
Rated short-time withstand current, 3 s	25 kA
Rated peak withstand current at 50/60 Hz	63 kA
Rated short-circuit breaking current	25 kA
Rated short-circuit making current at 50/60 Hz	63 kA
Rated normal current of busbar	2500 A
Rated normal current of feeders – with circuit-breaker – with fused load break switch	2500 A As per fuse

Classification of the SIMOPRIME A4 switchgear according to IEC 62271-200

Internal arc classification		
Classification	IAC	
Accessibility	Type A	
– Front	Type A	
– Rear	Type A	
– Lateral	Type A	
Test current	kA	25
Arc duration	s	1.0

Construction and design	
Partition class	PM (metallic partition)
Loss of service continuity category	LSC2B (metal-clad)
Compartment accessibility (standard)	Tool-based
– Busbar compartment	Interlock-controlled
– Switching-device compartment	Tool-based
– Low-voltage compartment	Interlock-controlled
– Connection compartment	and
– Front connection	Tool-based
– Rear connection	Tool-based

Dimensions

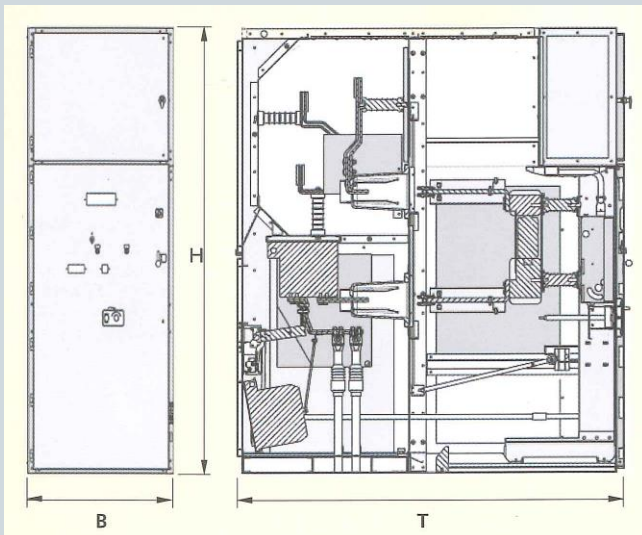

Room planning (room height ≥ 2850 mm)

Front connection

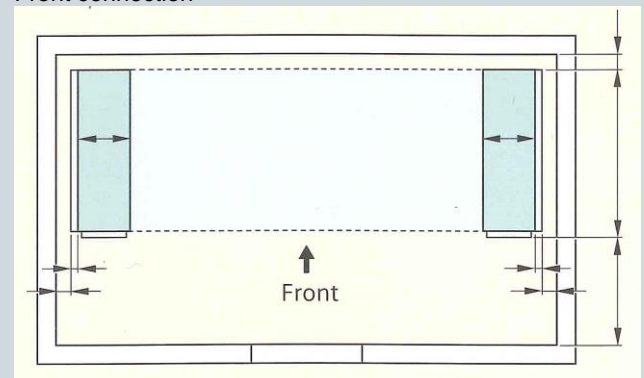

Single-row arrangement (plan view)

For dimensions B (width) and T (depth) refer to table on this page

- 1) For panel replacement: Control aisle 2000 mm
- 2) Minimum distance to wall 150 mm

All panel types Dimensions in mm







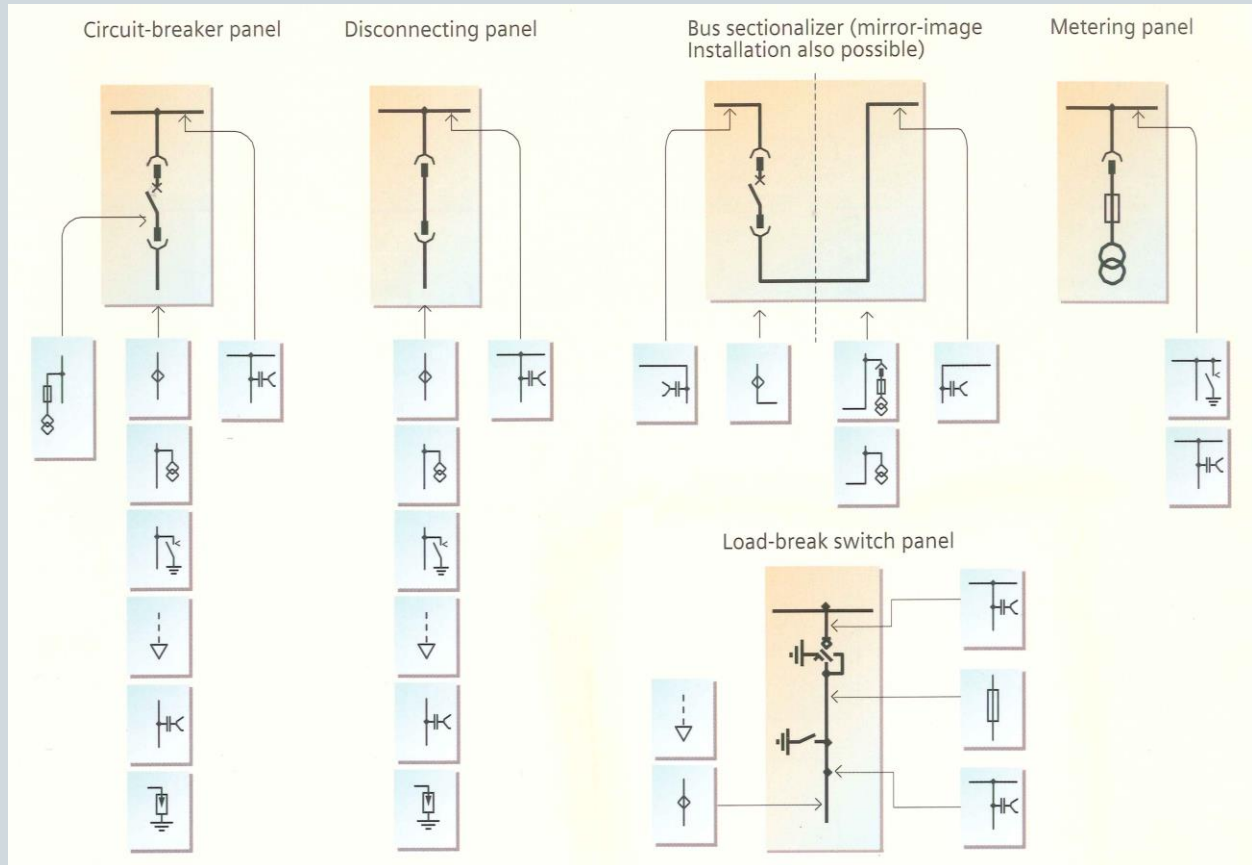





Width	B	Circuit-breaker panel for 1250 A	800
		for 2000 A	1000
		Load Break Switch	500
Height	H	With standard low-voltage compartment and IAC 0.1 s	2250
Depth	T	Standard	1900

Product Range

Panels



Components

	Current transformer		Withdrawable voltage transformer with primary fuses		HV HRC fuse
	Voltage transformer without primary fuses		Make-proof earthing switch		3AH5 vacuum circuit-breaker
	Voltage transformer with primary fuses		Disconnecting link or dummy truck		Three-position Switch-disconnector
	Capacitive voltage detection system		Cable sealing ends ¹⁾ max. 4 x 500 mm ² per phase		Surge arrestor

1) The details refer to conventional RXS single-core sealing ends for XLPE cables or other makes with similar dimensions.

Legend for panel design:

1. Door of low-voltage compartment
2. Opening for locking or unlocking the low-voltage compartment door
3. Option: Capacitive voltage detecting system for feeder and busbar
4. High-voltage door
5. Inspection window for checking the switching-device truck
6. Opening for locking or unlocking the high-voltage door
7. Opening for mechanical charging of circuit-breaker closing spring
8. Openings for manual operation (ON/OFF) of the circuit-breaker
9. Inspection window for reading the indicators
10. Door handle
11. Openings for switching-device truck operation
12. Opening for earthing-switch operation
13. Pressure relief duct
14. Busbars
15. Bushings
16. Post insulators
17. Block-type current transformer
18. Option: Make-proof earthing switch
19. Cable sealing ends
20. Option: Voltage transformer
21. Earthing busbar
22. Low-voltage plug connector
23. Vacuum interrupters

Basic panel design (example)

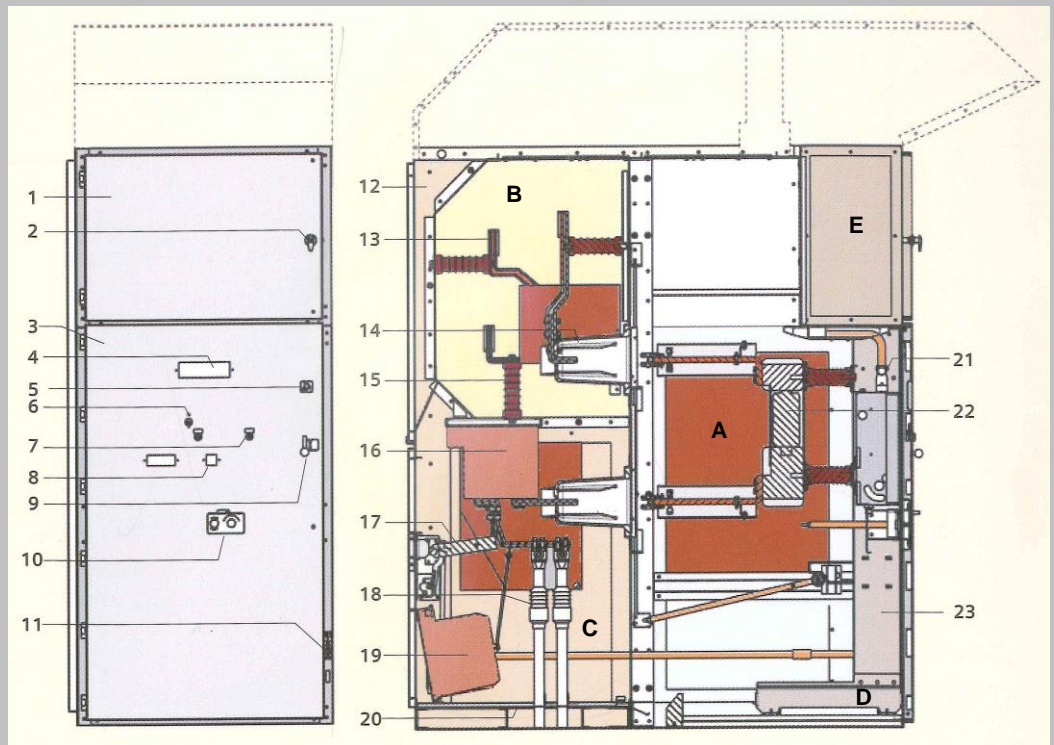

Circuit-breaker panel

Design:
Connection from front with block current transformer

- A** Switching-device compartment
- B** Busbar compartment
- C** Connection compartment
- D** Vacuum circuit-breaker truck
- E** Low-voltage compartment

Switching-device Compartment

- All switching operations with high-voltage door closed
- Pressure relief upwards
- Panel powder-coated with epoxy resin
- Shutter operating mechanisms separately for
 - Busbar compartment
 - Connection compartment
- Metallic, earthed shutters and partitions ensure partition class PM
- High-voltage door pressure-resistant in the event of internal arcs in the panel
- Metallic ducts on the side for laying control cables
- Interlocking between high-voltage door and circuit-breaker truck ensures interlock-based access
- Switching-device compartment to accommodate components for implementing various panel versions with
 - Vacuum circuit-breaker with or without voltage transformers on the truck
 - Disconnecter truck
 - Metering truck

Busbar compartment

- Pressure relief upwards and through rear pressure relief duct
- Option: Busbar transverse partition between panels
- Busbars made of flat copper, bolted from panel to panel
- For rated normal currents up to 2500 A
- Option: Insulated busbars
- Bolted top covers provide tool-based access
- Option: Coupling electrode for capacitive voltage detecting system
- Options: Possibility of installing the following components
 - Voltage transformers
 - Busbar earthing switch
 - Current transformers in the run of busbars

Connection compartment

- Pressure relief upwards through rear pressure relief duct
- Suitable for connection of
 - Single-core XLPE cables up to max. 4 x 500 mm² per phase
 - Three-core XLPE cables up to max. 3 x 300 mm² per panel
- Shutters to be opened separately to permit cable testing
- Earthing busbar
- Connection from front or rear
- Use of block-type current transformers
- Bolted rear covers of the connection compartment provide tool-based access for panels with connection from rear
- Interlocked high-voltage door and bolted partitions between connection compartment and switching-device compartment provide interlock-based and tool-based access for panels with connection from front

Components at the panel connection (option)

- Coupling electrode for capacitive voltage detecting system
- Voltage transformers
 - Cast-resin insulated
 - Max. 3 x 1-pole
 - Fixed-mounted, without primary fuses
- Make-proof earthing switches
 - With manual operating mechanism
 - In addition to standard interlocking of earthing switch/ circuit-breaker truck, optionally lockable or with electromagnetic interlock
- Surge arresters
 - Surge arresters for protecting the switchgear against external overvoltages

Interlocks

- Interlocking conditions are satisfied according to IEC 62271-200 / VDE 0671-200
- Earthing switch can only be operated with circuit-breaker truck in test position
- Circuit-breaker truck can only be moved with circuit-breaker "OPEN" and earthing switch "OPEN"
- Mechanical coding on the circuit-breaker truck prevents insertion of similar circuitbreaker trucks for lower rated normal currents into panels with higher rated normal currents
- Interlocking of high-voltage door against circuit-breaker truck
- The high-voltage door can only be opened when the circuit-breaker truck is in test position
- Option: Electromagnetic interlocks

Low-voltage compartment

- For accommodation of all protection, control, measuring and metering equipment
- Partitioned safe-to-touch from the high-voltage part
- Low-voltage compartment can be removed, bus wires and control cables are plugged in

Low-voltage cables

- Control cables of the panel are flexible and have metallic covers
- Connection of switching-device truck and panel wiring to low-voltage compartment via 64-pole coded plug connectors
- Bus wires are pluggable from panel to panel
- Option: Fire-resistance control wiring 1

Benefits	Features
<ul style="list-style-type: none"> • Saves lives 	<ul style="list-style-type: none"> • All switching operations including emergency manual operations with high-voltage door closed • Interlocking between high-voltage door and switching devices • Rack-in, rack-out operations of the circuit-breaker truck with high-voltage door closed • Metallic, earthed shutters and partitions, partition class: PM (metallic partition) • Internal arc tested design up to 25 kA, 1 s, according to IEC 62271-200 • Use of vacuum circuit-breakers
<ul style="list-style-type: none"> • Peace of mind 	<ul style="list-style-type: none"> • Factory-assembled, type-tested switchgear according to IEC 62271-200 • Type testing of the circuit-breaker inside the panel • Use of standard, world-wide available components • Use of maintenance-free vacuum circuit-breakers • Quality management according to DIN EN ISO 9001 • Design based on global best practice sharing and experience • More than 300,000 air-insulated switchgear panels from Siemens in operation world-wide
<ul style="list-style-type: none"> • Increases productivity 	<ul style="list-style-type: none"> • Use of metallic, earthed shutters and partitions between the compartments ensures highest loss of service continuity of the switchgear (LSC2B according to IEC 62271-200) during maintenance • Use of maintenance-free vacuum circuit-breakers
<ul style="list-style-type: none"> • Saves money 	<ul style="list-style-type: none"> • Use of maintenance-free vacuum circuit-breakers

Truck-type design



Standards (March 2008)

The switchgear complies with the relevant standards and specifications applicable at the time of type tests.

In accordance with the harmonization agreement reached by the EU countries, their national specifications conform to the IEC standard.

Overview of standards

		IEC standard	VDE standard	EN standard
Switchgear	SIMOPRIME	IEC 62271-1	VDE 0671-1	EN 62271-1
		IEC 62271-200	VDE 0671-200	EN 62271-200
Devices	Circuit-breaker	IEC 62271-100	VDE 0671-100	EN 62271-100
	Disconnecter and earthing switch	IEC 62271-102	VDE 0671-102	EN 62271-102
	Switch	IEC 62265-1	VDE 0671-103	EN 60265-1
	Switch-fuse combination	IEC 62271-105	VDE 0671-105	EN 62271-105
	HV HRC fuses	IEC 60282	VDE 0670-4	EN 60282
	Voltage detecting systems	IEC 61243-5	VDE 0682-415	EN 61243-5
Degree of protection	–	IEC 60529	VDE 0470-1	EN 60529
Insulation	–	IEC 60071	VDE 0111	EN 60071
Instrument transformers	Current transformer	IEC 60044-1	VDE 0414-1	EN 60044-1
	Voltage transformer	IEC 60044-2	VDE 0414-2	EN 60044-2
Installation	–	IEC 62271	VDE 0101	–

Type of service location

The switchgear can be used for indoor installation in accordance with IEC 61936 (Power installations exceeding 1 kV AC) and VDE 0101

- Outside lockable electrical service locations at places which are not accessible to the public. Enclosures of switchgear can only be removed with tools.
- Inside lockable electrical service locations. A lockable electrical service location is a place outdoors or indoors that is reserved exclusively for housing electrical equipment and which is kept under lock and key. Access is restricted to authorized personnel and persons who have been properly instructed in electrical engineering. Untrained or unskilled persons may only enter under the supervision of authorized personnel or properly instructed persons.

Rated voltage (rms value)	kV	24
Rated short-duration power-frequency withstand voltage (rms value)		
– Across isolating distances	kV	60
– Between phases and to earth	kV	50
Rated lightning impulse withstand voltage (peak value)		
– Across isolating distances	kV	145
– Between phases and to earth	kV	125

Altitude correction factor K_a

For site altitudes above 1000m, the altitude correction factor K_a is recommended, depending on the actual site altitude above sea level.

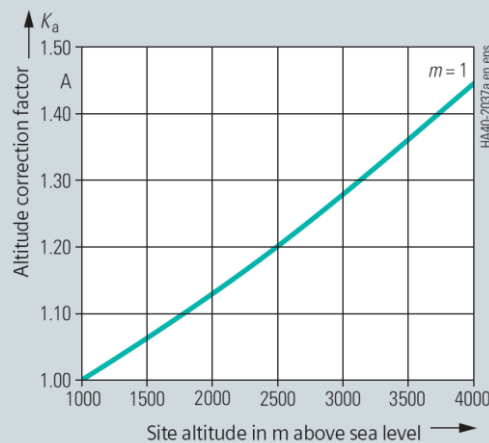

Rated short-dur. power-freq. withstand volt. to be selected for site altitudes > 1000m

≥ Rated short-duration power-frequency withstand voltage up to ≤ 1000m · K_a

Rated lightning impulse withstand volt. to be selected for site altitudes > 1000m

≥ Rated lightning impulse withstand voltage up to ≤ 1000m · K_a

Example:

1800m site altitude above sea level
 12 kV switchgear rated voltage
 75 kV rated lightning impulse withstand voltage
 Rated lightning impulse withstand voltage to be selected $75 \text{ kV} \cdot 1.10 = 82.5 \text{ kV}$

Result:

According to the above table, a switchgear for a rated voltage of 17.5 kV is to be selected.

Dielectric strength

- The dielectric strength is verified by testing the switchgear with rated values of shortduration power-frequency withstand voltage and lightning impulse withstand voltage according to IEC 62271-1 / VDE 0671-1 (see table “Dielectric strength”).
- The rated values are referred to sea level and to normal atmospheric conditions (1013 hPa, 20 °C, 11 g/m³ humidity in accordance with IEC 60071 / VDE 0111).
- The dielectric strength decreases with increasing altitude. For site altitudes above 1000 m (above sea level) the standards do not provide any guidelines for the insulation rating. Instead, special arrangements apply to these altitudes.
- Site altitude
 - As the altitude increases, the dielectric strength in air decreases due to the decreasing air density. This reduction is permitted up to a site altitude of 1000 m according to IEC and VDE.
 - For site altitudes above 1000 m, a higher insulation level must be selected. It results from the multiplication of the rated insulation level for 0 to 1000 m with the altitude correction factor K_a .

Terms

“Make-proof earthing switches” are earthing switches with short-circuit making capacity according to

- IEC 62271-102 and
- VDE 0671-102 / EN 62271-102

Internal arc classification

- Protection of operating personnel by means of tests for verifying the internal arc classification
- Internal arcing tests must be performed in accordance with IEC 62271-200 / VDE 0671-200
- The switchgear complies with criteria 1 to 5 specified in the mentioned standards for the basic version up to 25 kA.
- Definitions of the criteria:
 - Criterion 1
Correctly secured doors and covers do not open. Limited deformations are accepted.
 - Criterion 2
No fragmentation of the enclosure. Projection of small parts up to an individual mass of 60 g are accepted.
 - Criterion 3
Arcing does not cause holes in the accessible sides up to a height of 2 m.
 - Criterion 4
Horizontal and vertical indicators do not ignite due to the effect of hot gases.
 - Criterion 5
The enclosure remains connected to its earthing point.

Current-carrying capacity

- According to IEC 62271-1 / VDE 0671-1 and IEC 62271-200 / VDE 0671-200 current carrying capacities refer to the following ambient air temperatures:
 - Maximum of 24-hour mean + 35 °C
 - Maximum + 40 °C
- The current-carrying capacity of the panels and busbars depends on the ambient air temperature outside the enclosure.
- To attain the maximum rated normal currents, the panels are provided with natural or forced ventilation.

Climate and environmental influences

The switchgear may be used, subject to possible additional measures, under the following environmental influences and climate classes:

Environmental influences

- Natural foreign materials
- Chemically active pollutants
- Small animals

Climate classes

- 3K3
- 3K5

The climate classes are classified according to IEC 60721-3-3.

Protection against solid foreign bodies, electric shock and ingress of water

SIMOPRIME switchgear fulfills acc. to the standards

- IEC 62271-200
- IEC 60529
- VDE 0470-1
- VDE 0671-200

the following degrees of protection:

- **Enclosure:**
IP 4X (protection against solid foreign bodies)
- **Compartments:**
IP 2X (protection against solid foreign bodies)
Higher degree of protection for enclosure on request.

Notes

If not stated otherwise on the individual pages of this catalog, we reserve the right to include modifications, especially regarding the stated values, dimensions and weights. Drawings are not binding.

All product designations used are trademarks or product names of Siemens AG or other suppliers.

If not stated otherwise, all dimensions in this catalog are given in mm.

The information in this document contains general descriptions of the technical options available, which do not always have to be present in individual cases. The required features should therefore be specified in each individual case at the time of closing the contract.



Printed on elementary chlorine-free bleached paper.

All rights reserved.

If not stated otherwise on the individual pages of this catalog, we reserve the right to include modifications, especially regarding the stated values, dimensions and weights. Drawings are not binding.

All product designations used are trademarks or product names of Siemens AG or other suppliers.

If not stated otherwise, all dimensions in this catalog are given in mm.

Subject to change without prior notice.

The information in this document contains general descriptions of the technical options available, which may not apply in all cases. The required technical options should therefore be specified in the contract.

EDH.,JSC

Medium Voltage

Lot 2-CN3, Ngoc Hoi Industrial Zone

Ngoc Hoi Commune, Thanh Tri District

Hanoi, Vietnam

www.edh.com.vn

For more information, please contact us

Phone: +84 4 3783 0057

Fax: +84 4 3783 0059

(Charges depending on provider)

E-mail: edh@edh.com.vn